Cromatix Ultra-Efficient Solid State Light (U-ESSL) Ground Light Fittings

Datasheet and Operating Guide



The Cromatix U-ESSL is a light source that delivers the promised LED lighting revolution to home and commercial applications in a range of highly cost effective packages. Through the use of energy-efficient, environmentally friendly LED lighting, the U-ESSL and associated products render traditional incandescent lighting obsolete.

The LED arrays feature the lowest thermal transfer available, thus giving the user maximum output, maximum life and lowest running costs. Each light comes with a carbon offset statement and a class-leading three year warranty. In the IP68 version the LEDs are totally encapsulated for long term protection against moisture ingress.

The U-ESSL is available in warm white, neutral white and for mood-lighting applications, RGB. The RGB version requires an RGB driver and controller. This can either be through standard DMX, or via virtually any RGB colour controller. The white units require connection to a constant-current 350mA / 700mA LED driver.

Outline Drawing

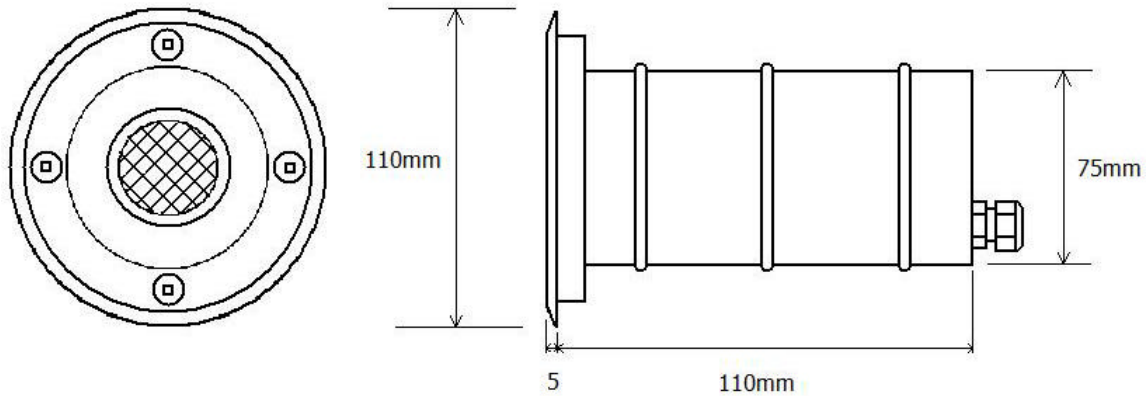

Technical Specifications

- Upto 280 Lumens available from class-leading high efficiency LEDs
- Die Technology: InGaN
- 20, 38 and 57 degree beam angles available
- Available in warm white, daylight white & RGB
- LED life 50,000 hours min
- Cast aluminium body, powder coated
- Stainless steel rim and fixings
- Toughened borosilicate lens
- Total Max Power: 3W / 4.2W / 7W (RGB Only)
- Operating Environment: IP65 (IP68 available as an option)
- Operating Temperature -30C to 50C
- Can be painted to any RAL/BS colour to order
- Monochrome versions available to order

Part Number Identification (add suffix -IP for IP68)

Part Number	Colour	Operating Current	Typical Voltage	Colour Temperature	Colour Resolution	Typical Lumens
CRGLWW-C	Warm	350mA	11.2v	3050°K	78	280Lm
CRGLNW-C	Neutral	350mA	11.4v	4200°K	82	230Lm
CRGLWW-A	Warm	700mA	4.0v	3050°K	74	125Lm
CRGLRGB	RGB	350mA per colour	R 4.6v G 7.2v B 7.0v	-	-	212Lm

Warranty

36 months unconditional from date of purchase. For product support, please contact info@ledlightingproducts.co.uk



Product Disposal

LED Lighting Products Ltd is obliged under The Waste Electrical and Electronic Equipment (WEEE) Directive to offer our customers free take-back of their WEEE on a like-for-like basis when they buy a new electrical/electronic product from us. This is to prevent it going into a landfill site, thereby saving the UK's natural finite resources and reducing the environmental and health risks associated with sending electrical goods to landfill.

Goods marked with the above symbol show that they were produced after 13th August 2005 and should be disposed of separately from normal household waste so that they can be safely recycled.

Customers returning any WEEE items to us must do so within 28 days of purchasing their new item at their own expense.